

WEVO

Stock 911 PSJ

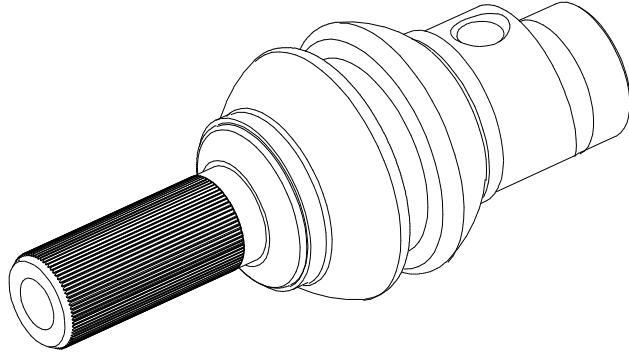

The WEVO Stock 911 PSJ, is a high performance upgrade for your 911 shift linkage mechanism.

This unit is a direct replacement for the O.E. coupler used in all 911 series chassis using the 901, 911, 915 and 930 transmissions - including all 912's.

The WEVO Stock 911 PSJ can be installed with the original shift tube clamp and original M8 conical nosed set screw.

The installation of this unit as a replacement of your O.E. shift coupler will improve accuracy of the shift linkage. It will eliminate "lost motion" where it existed due to original design considerations for NVH (Noise, Vibration, Harshness) and wear and tear due to use and age.

For cars using a stock shifter, the set-up of the WEVO Stock 911 PSJ should be performed as per the O.E. coupler.

If you are using an aftermarket shifter of any kind, follow the set-up instructions peculiar to that shifter unit.

The WEVO Stock 911 PSJ is a service free design. The neoprene boot is designed keep dirt from the mechanism. The boot is removable for cleaning and inspection purposes, should the need arise. When the joint is installed, check to ensure that the boot is correctly seated in the retaining groove and not dislodged during installation.

Due to tight manufacturing tolerances, the WEVO Stock 911 PSJ may feel different on the two pivot axis. This is no cause for concern, the unit will perform perfectly once installed and being used.

You may experience a modest increase in transmission noise transmitted to the driver cabin, this is also normal and a result of the precision achieved by the elimination of the factory plastic bushings and lost motion in the O.E. architecture.

For additional improvements to your shifter mechanism also consider the following upgrades;

WEVO Shifter, 901, 915 or 930 versions	\$ 655.00
WEVO XT_147 PSJ Billet Clamp	\$ 39.50
WEVO 915 GateShift kit	\$ 895.00
WEVO SS Engine Mounts (Semi-Solid)	\$ 94.75 ea